

# SAC1411

## Legend

- 1 Return Air
- 2 Control Pad
- 3 Cold Air Supply
- 4 Condenser Air Inlet
- 5 Condenser Air Outlet
- 6 Power Cord
- 7 Condensate Nipple
- 8 Condensate Alarm Jack
- 9 Access Door

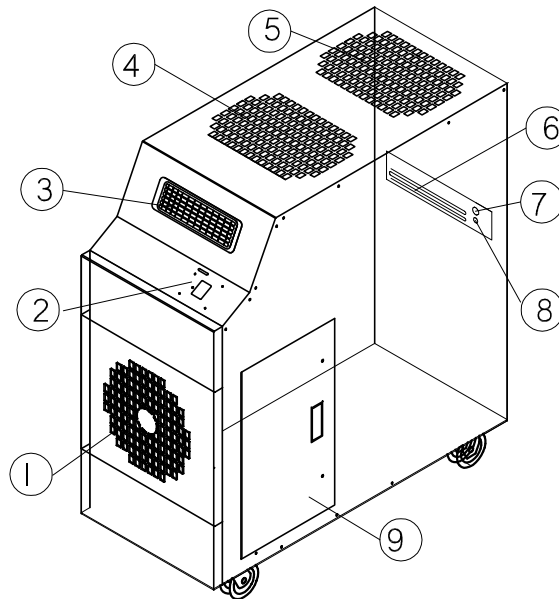

Isometric View

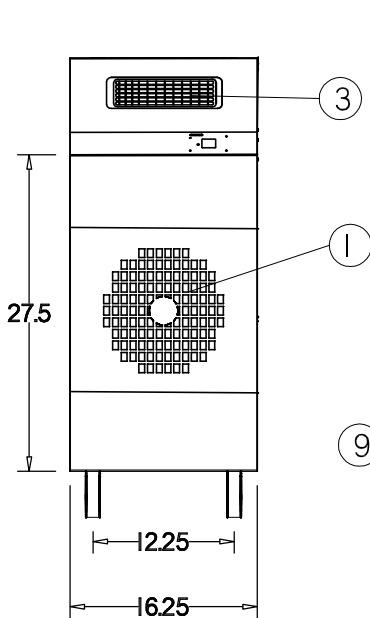

Front View

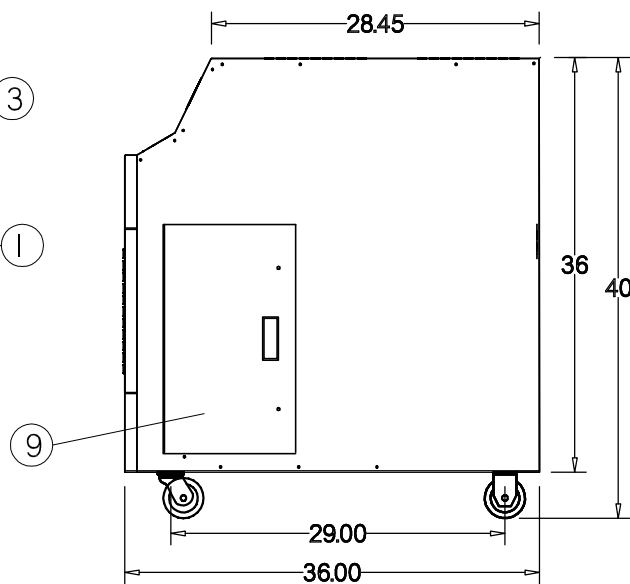

Right View



ETL LISTED CONFORMS TO ANSI/UL  
1995 CERTIFIED TO CAN/CSAA22.2 NO.235

**Kwikool**

**1-800-KWIKOOL**

# SPECIFICATIONS

## Model SAC1411 - 1.1 Ton

COOLING CAPACITY		
	BTU/hr @ 95 F at 60%RH	13,850 (1.1 TON)
COMPRESSOR DATA		
	Compressor Type	HERMETIC ROTARY
	Operating Temperatures	60-110 F .50%RH
	Refrigerant	R-22
FAN DATA		
EVAPORATOR		
	Fan Type (Centrifugal)	DIRECT DRIVE
	Air Flow (CFM)	460/3 Speed
	Supply Air chute Data	ADJUSTABLE VENT
	Supply Air Chute Data (Optional)	2-5"Dia.x12"Length
	Motor HP	1/6
CONDENSER		
	I/O Intergral Condenser - In/Out	BALANCED AIR FLOW
	Fan Type (Centrifugal)	DIRECT DRIVE
	Air Flow (CFM)	1100
	Condenser Duct Data (Optional)	2x12"Dia.x8' Length
	Condenser Duct Max. Length	25'
	Motor HP	1/3
ELECTRICAL DATA		
	Power Supply (Volts)	115/Single Phase
	Current Consumption (Amps)	14.5
	Power Consumption (KW)	1.35
	Maximum Circuit Breaker (Amps)	20
	Minimum Circuit Ampacity (Amps)	17.24
	Min/Max Voltage	105-125
	Power Cord Gauge/Length	14/6'
	Plug Configuration	NEMA 5-15
DIMENSIONAL DATA		
Unitary Models	Width x Depth x Height (Inches)	16.25X36X40
	Weight (Lbs.)	211
	Shipping Weight (Lbs.)	286
	Ceiling Kit - CK-12 Weight	38
	Total Shipping Weight/w Ceiling Kit	339
SAFETY DEVICE DATA		
	Compressor Overload	INTERNAL
	Fan Motor Overload	AUTOMATIC INTERNAL
	Evaporator Freeze-up	HOT GAS BYPASS
	High Pressure Switch	MANUAL
	Low Pressure Switch	AUTOMATIC
	Compressor Short Cycle	YES
	Automatic Restart	YES
	Thermostat	MICROPROCESSOR/ DIGITAL
	Condensate Pump w 20' Head Pres.	YES
	Condensate Pump Overflow	YES
	Condensate Tank Overflow	YES



**1-800-KWIKOOL**