

SAC6021

Legend

- 1 Return Air
- 2 Control Pad
- 3 Cold Air Supply
- 4 Condenser Air Inlet
- 5 Condenser Air Outlet
- 6 Power Cord
- 7 Condensate Nipple
- 8 Condensate Alarm Jack
- 9 Access Door

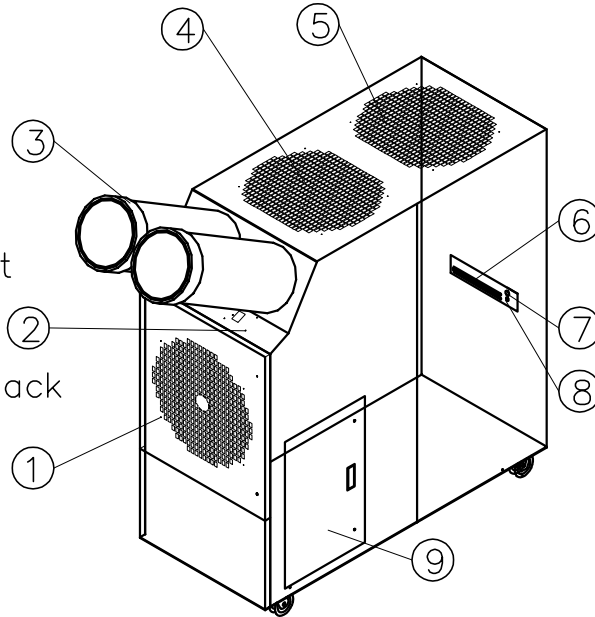

Isometric View

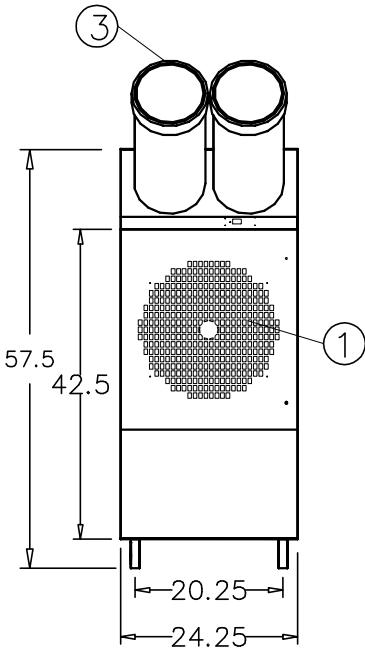

Front View

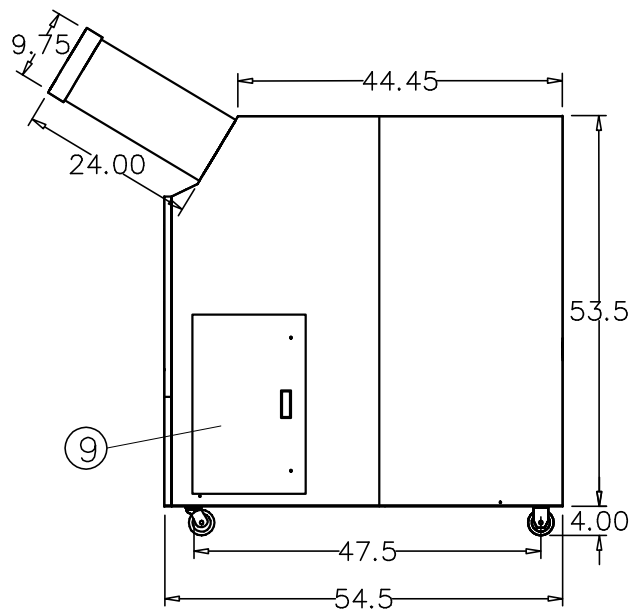

Right View



ETL LISTED CONFORMS TO ANSI/UL
1995 CERTIFIED TO CAN/CSAA22.2 NO.235

KwikKool

1-800-KWIKOOL

SPECIFICATIONS

Model SAC6021 - 5 Ton

COOLING CAPACITY		
	BTU/hr @ 95 F at 60%RH	60000 (5 TON)
COMPRESSOR DATA		
	Compressor Type	HERMETIC RECIP.
	Operating Temperatures	60-110 F .50%RH
	Refrigerant	R-22
FAN DATA		
EVAPORATOR		
	Fan Type (Centrifugal)	DIRECT DRIVE
	Air Flow (CFM)	2000/3 Speed
	Supply Air Chute Data	2-10" Dia. x 24" Length
	Supply Air Chute Max. Length	50'
	Motor HP	1
CONDENSER		
	I/O Intergral Condenser - In/Out	BALANCED AIR FLOW
	Fan Type (Centrifugal)	BELT DRIVE
	Air Flow (CFM)	3500
	Condenser Duct Data (Optional)	2-20" Dia. x 8' Length
	Condenser Duct Max. Length	65'
	Motor HP	3
ELECTRICAL DATA		
	Power Supply (Volts)	208/230 Single phase
	Current Consumption (Amps)	45.5
	Power Consumption (KW)	8.8
	Maximum Circuit Breaker (Amps)	60 at 208-V/50 at 230-V
	Minimum Circuit Ampacity (Amps)	50
	Min/Max Voltage	195-225/210-250
	Power Cord Gauge/Length	8AWG/10
	Plug Configuration	FIELD SUPPLIED
DIMENSIONAL DATA		
Unitary Models	Width x Depth x Height (Inches)	24.25X54.5X57.5
	Weight (Lbs.)	557
	Shipping Weight (Lbs.)	657
	Ceiling Kit - CK-60 Weight	56
	Total Shipping Weight/w Ceiling Kit	728
SAFETY DEVICE DATA		
	Compressor Overload	INTERNAL
	Fan Motor Overload	AUTOMATIC INTERNAL
	Evaporator Freeze-up	HOT GAS BYPASS
	High Pressure Switch	MANUAL
	Low Pressure Switch	AUTOMATIC
	Compressor Short Cycle	YES
	Automatic Restart	YES
	Thermostat	MICROPROCESSOR/ DIGITAL
	Condensate Pump w 20' Head Pres.	YES
	Condensate Pump Overflow	YES
	Condensate Tank Overflow	YES



1-800-KWIKOOL