

SPLAC2411

Legend

- 1 Return Air
- 2 Control pad
- 3 Cold Air Supply
- 4 Power Cord
- 5 Condensate Nipple
- 6 Condensate Alarm Jack
- 7 Access Door
- 8 Flexible Cable Connector (3"φ x 20')

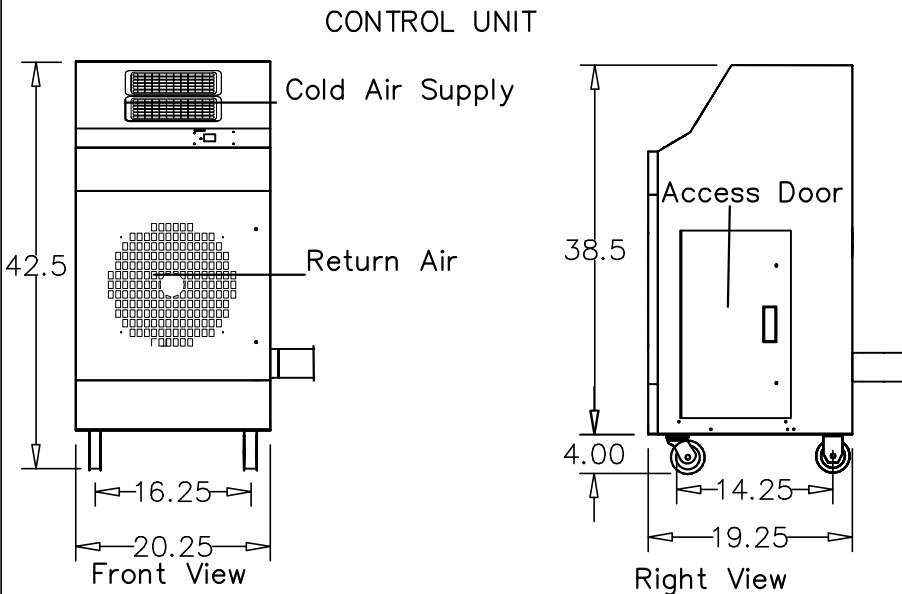
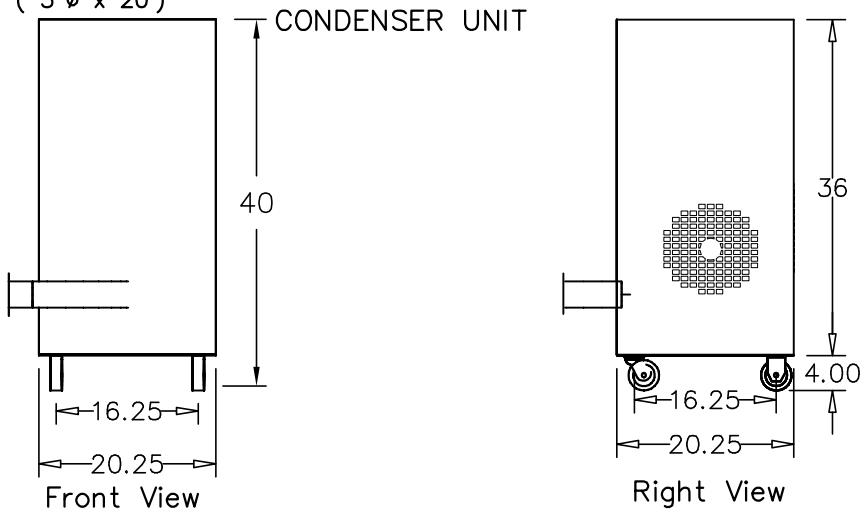
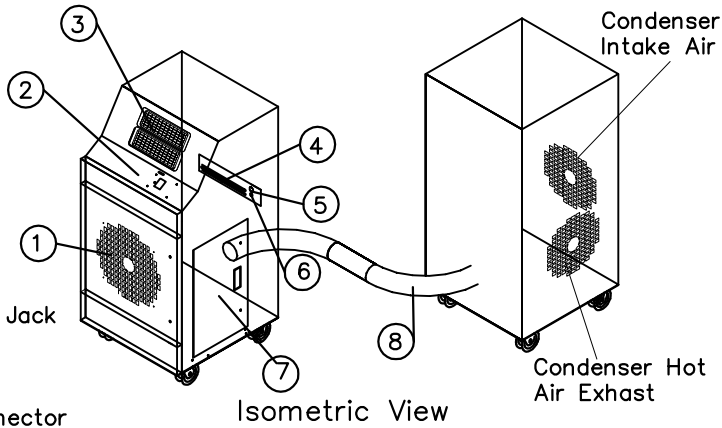

ETL LISTED CONFORMS TO ANSI/UL
1995 CERTIFIED TO CAN/CSAA22.2 NO.235



1-800-KWIKOOL

SPECIFICATIONS

Model SPLAC2411 - 2 Ton

COOLING CAPACITY		
	BTU/hr @ 95 F at 60%RH	23,500 (2 TONS)
COMPRESSOR DATA		
	Compressor Type	HERMETIC ROTARY
	Operating Temperatures	60-110 F .50%RH
	Refrigerant	R-22
FAN DATA		
EVAPORATOR		
	Fan Type (Centrifugal)	DIRECT DRIVE
	Air Flow (CFM)	725/Single Speed
	Supply Air Chute Data	ADJUSTABLE VENT
	Supply Air Chute Kit (Optional)	2-6"Dia.x15"Length
	Motor HP	1/5
CONDENSER		
	I/O Intergral Condenser - In/Out	BALANCED AIR FLOW
	Fan Type (Centrifugal)	DIRECT DRIVE
	Air Flow (CFM)	1350
	Condenser Exhaust Duct (Optional)	1x14"Dia.x8' Length
	Condenser Duct Max. Length	25'
	Motor HP	1/4
ELECTRICAL DATA		
	Power Supply (Volts)	115/Single Phase
	Current Consumption (Amps)	19.5
	Power Consumption (KW)	2
	Maximum Circuit Breaker (Amps)	20
	Minimum Circuit Ampacity (Amps)	20.1
	Min/Max Voltage	105-125
	Power Cord Gauge/Length	12AWG/6
	Plug Configuration	NEMA 5-20
DIMENSIONAL DATA		
SPLAC Model (Master)	Width x Depth x Height (Inches)	20.25X19.25X42.5
(Slave)	Width x Depth x Height (Inches)	20.25X20.25X40
	Weight (Lbs.)	338
	Shipping Weight (Lbs.)	413
SAFETY DEVICE DATA		
	Compressor Overload	INTERNAL
	Fan Motor Overload	AUTOMATIC INTERNAL
	Evaporator Freeze-up	HOT GAS BYPASS
	High Pressure Switch	MANUAL
	Low Pressure Switch	AUTOMATIC
	Compressor Short Cycle	YES
	Automatic Restart	YES
	Thermostat	MICROPROCESSOR/ DIGITAL
	Condensate Pump w 20' Head Pres.	YES
	Condensate Pump Overflow	YES
	Condensate Tank Overflow	YES



1-800-KWIKOOL