

SWAC3021

Legend

- 1 Return Air
- 2 Control Pad
- 3 Cold Air Supply
- 4 Power Cord
- 5 1/2" Female water Hose Connector (Inlet/Outlet)
- 6 Condensate Nipple
- 7 Condensate Alarm Jack
- 8 Access Door

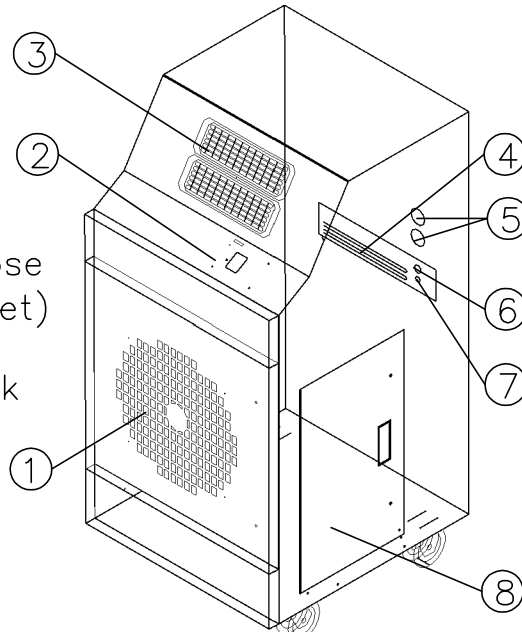

Isometric View

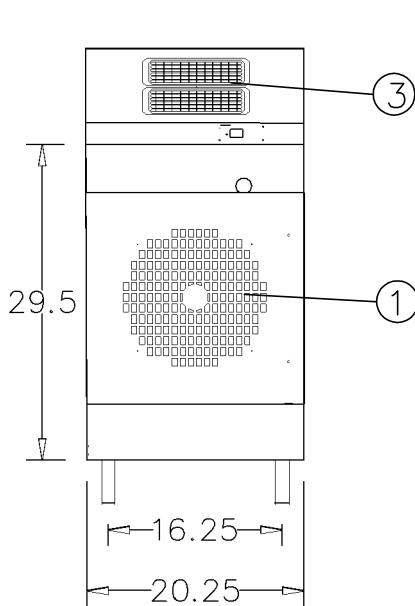

Front View

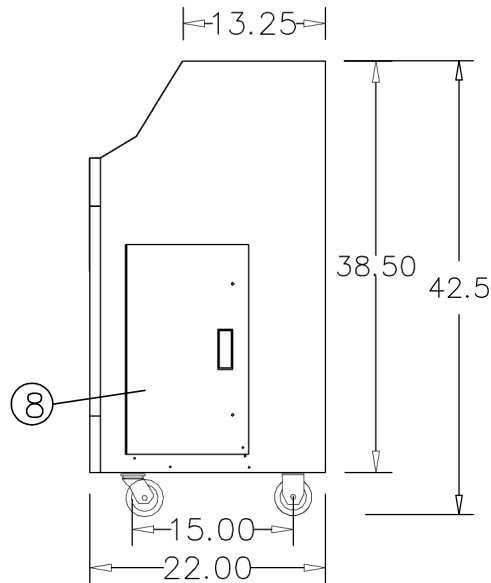

Right View



ETL LISTED CONFORMS TO ANSI/UL
1995 CERTIFIED TO CAN/CSAA22.2 NO.235



1-800-KWIKOOL

SPECIFICATIONS

Model SWAC3021 - 2.5 Ton

COOLING CAPACITY		
	BTU/hr @ 95 F at 60%RH	29,500 (2.5 TONS)
COMPRESSOR DATA		
	Compressor Type	HERMETIC RECIP.
	Operating Temperatures	60-110 F .50%RH
	Refrigerant	R-22
FAN DATA		
EVAPORATOR		
	Fan Type (Centrifugal)	DIRECT DRIVE
	Air Flow (CFM)	850/3 Speed
	Supply Air Chute Data	ADJUSTABLE VENT
	Supply Air Chute Kit (Optional)	2-6" Dia. x 15" Length
	Motor HP	1/3
WATER FLOW DATA		
	Flow Regulation Valve	AUTOMATIC
	Inlet Water 85F-95F Exit(GPM)	7.5
	Inlet Water 75F-95F Exit(GPM)	3.75
	Inlet Water 65F-95F Exit(GPM)	2.5
	Inlet Water 55F-95F Exit(GPM)	2
ELECTRICAL DATA		
	Power Supply (Volts)	208/230-Single Phase
	Current Consumption (Amps)	12.65/11.5
	Power Consumption (KW)	2.25
	Maximum Circuit Breaker (Amps)	20
	Minimum Circuit Ampacity (Amps)	14.45
	Min/Max Voltage	195-225/210-250
	Power Cord Gauge/Length	12AWG/6
	Plug Configuration	NEMA 6-20
DIMENSIONAL DATA		
Unitary Models	Width x Depth x Height (Inches)	20.25X22X42.5
	Weight (Lbs.)	208
	Shipping Weight (Lbs.)	283
SAFETY DEVICE DATA		
	Compressor Overload	INTERNAL
	Fan Motor Overload	AUTOMATIC INTERNAL
	Evaporator Freeze-up	HOT GAS BYPASS
	High Pressure Switch	MANUAL
	Low Pressure Switch	AUTOMATIC
	Compressor Short Cycle	YES
	Automatic Restart	YES
	Thermostat	MICROPROCESSOR/ DIGITAL
	Condensate Pump w 20' Head Pres.	YES
	Condensate Pump Overflow	YES
	Condensate Tank Overflow	YES



1-800-KWIKOOL